

# UEX

ECONOMICAL  
SOLUTIONS

AL- General Type Hardened Coated  
End Mill (Black) HRC60

AL-通用加硬塗層銑刀（黑色）HRC60度

AS- General Type Hardened Coated  
End Mill (Bronze) HRC60

AS-通用型塗層銑刀（古銅色塗層）HRC60度

Micro Diameter End Mill (Minimum Diameter:0.09mm)



TUNGSTEN CARBIDE

[www.dohrecnc.com](http://www.dohrecnc.com)

# UEX 6 flutes square end mills

6刃立铣刀



UMG 0.5 μm CO10% HRC-60 AITINL AITINS

B127

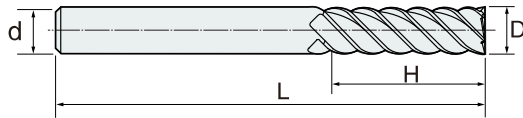

Product Code 產品編號	Blade diameter 刃徑	Blade length 刃長	Full 全長	Shank 柄徑	Inventory 庫存	
					AL	AS
UEX6F04001105006	4.0	11	50	6	◎	◎
UEX6F05001305006	5.0	13	50	6	◎	◎
UEX6F06001505006	6.0	15	50	6	◎	◎
UEX6F08002006008	8.0	20	60	8	◎	◎
UEX6F10002507510	10.0	25	75	10	◎	◎
UEX6F12003007512	12.0	30	75	12	◎	◎
UEX6F16004010016	16.0	40	100	16	◎	◎
UEX6F20004010020	20.0	40	100	20	◎	◎
UEX6F25004510025	25.0	45	100	25	◎	◎

## ★ WORK MATERIAL 被削材質

UEX				
P20 S45C	SCM SK	FC FCD	CU	304
碳素鋼	合金鋼	鑄鐵	銅合金	不銹鋼
●	●	●	●	●

## ★ TOLERANCES 公差

Blade diameter 刃部直徑	Blade diameter tolerance 刃部直徑公差	Shank diameter tolerance 柄部直徑公差
Φ4.0~Φ6.4	-0.01~-0.03	H6
Φ6.5~Φ10.9	-0.01~-0.035	
Φ11.0~Φ16.5	-0.01~-0.04	
Φ17.0~Φ20.0	-0.015~-0.045	
Φ20.5~Φ25.0	-0.015~-0.05	

Order code: UEX 6F 040 011 050 06 AS  
 訂貨編號: D H L d HRC60  
 UEX 6F 040 011 050 06 AL  
 D H L d HRC60

# UEX Long flute 6 flutes square end mills

長刃型 6刃立銑刀



UMG 0.5 μm CO10% HRC-60 AITINL AITINS

B128

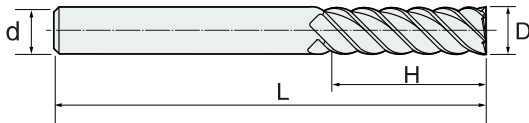

Product Code 產品編號	Blade diameter 刃徑	Blade length 刃長	Full 全長	Shank 柄徑	Inventory 庫存	
					AL	AS
UEX6F04001607506	4.0	16	75	6	⊙	⊙
UEX6F05002007506	5.0	20	75	6	⊙	⊙
UEX6F06002507506	6.0	25	75	6	⊙	⊙
UEX6F08003007508	8.0	30	75	8	⊙	⊙
UEX6F04002010006	4.0	20	100	6	⊙	⊙
UEX6F05002510006	5.0	25	100	6	⊙	⊙
UEX6F06003010006	6.0	30	100	6	⊙	⊙
UEX6F08003510008	8.0	35	100	8	⊙	⊙
UEX6F10004010010	10.0	40	100	10	⊙	⊙
UEX6F12004510012	12.0	45	100	12	⊙	⊙
UEX6F08005015008	8.0	50	150	8	⊙	⊙
UEX6F10005015010	10.0	50	150	10	⊙	⊙
UEX6F12005015012	12.0	50	150	12	⊙	⊙
UEX6F16007015016	16.0	70	150	16	⊙	⊙
UEX6F20007015020	20.0	70	150	20	⊙	⊙
UEX6F25008015025	25.0	80	150	25	⊙	⊙

## ★ WORK MATERIAL 被削材質

UEX				
P20 S45C	SCM SK	FC FCD	CU	304
碳素鋼	合金鋼	鑄鐵	銅合金	不銹鋼
●	●	●	●	●

## ★ TOLERANCES 公差

Blade diameter 刃部直徑	Blade diameter tolerance 刃部直徑公差	Shank diameter tolerance 柄部直徑公差
Φ4.0~Φ6.4	-0.01~-0.03	H6
Φ6.5~Φ10.9	-0.01~-0.035	
Φ11.0~Φ16.5	-0.01~-0.04	
Φ17.0~Φ20.0	-0.015~-0.045	
Φ20.5~Φ25.0	-0.015~-0.05	

# UEX2 flutes square end mills

2刃立铣刀

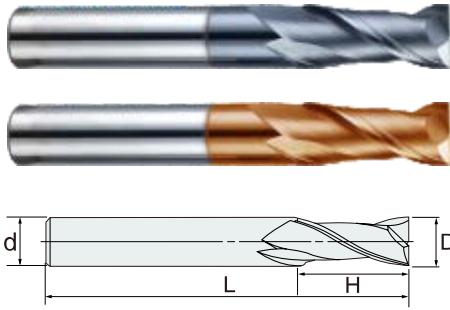

B129

Product Code 产品编号	Blade diameter 刃径	Blade length 刃长	Full 全长	Shank 柄径	Inventory 库存	
					AL	AS
UEX2F01003005004	1.0	3	50	4	○	○
UEX2F01504005004	1.5	4	50	4	○	○
UEX2F02006005004	2.0	6	50	4	○	○
UEX2F02507005004	2.5	7	50	4	○	○
UEX2F03008005004	3.0	8	50	4	○	○
UEX2F03510005004	3.5	10	50	4	○	○
UEX2F04011005004	4.0	11	50	4	○	○
UEX2F01003005006	1.0	3	50	6	○	○
UEX2F01504005006	1.5	4	50	6	○	○
UEX2F02006005006	2.0	6	50	6	○	○
UEX2F02507005006	2.5	7	50	6	○	○
UEX2F03008005006	3.0	8	50	6	○	○
UEX2F03510005006	3.5	10	50	6	○	○
UEX2F04011005006	4.0	11	50	6	○	○
UEX2F04513005006	4.5	13	50	6	○	○
UEX2F05013005006	5.0	13	50	6	○	○
UEX2F05513005006	5.5	13	50	6	○	○
UEX2F06015005006	6.0	15	50	6	○	○
UEX2F06517006008	6.5	17	60	8	○	○
UEX2F07017006008	7.0	17	60	8	○	○
UEX2F07517006008	7.5	17	60	8	○	○
UEX2F08020006008	8.0	20	60	8	○	○
UEX2F08523007510	8.5	23	75	10	○	○
UEX2F09023007510	9.0	23	75	10	○	○
UEX2F09525007510	9.5	25	75	10	○	○
UEX2F10025007510	10.0	25	75	10	○	○
UEX2F10525007512	10.5	25	75	12	○	○
UEX2F11028007512	11.0	28	75	12	○	○
UEX2F11528007512	11.5	28	75	12	○	○
UEX2F12030007512	12.0	30	75	12	○	○
UEX2F13040010014	13.0	40	100	14	○	○
UEX2F14040010014	14.0	40	100	14	○	○
UEX2F15040010016	15.0	40	100	16	○	○
UEX2F16040010016	16.0	40	100	16	○	○
UEX2F17040010018	17.0	40	100	18	○	○
UEX2F18040010018	18.0	40	100	18	○	○
UEX2F19040010020	19.0	40	100	20	○	○
UEX2F20040010020	20.0	40	100	20	○	○
UEX2F22040010025	22.0	40	100	25	○	○
UEX2F25040010025	25.0	40	100	25	○	○

★ WORK MATERIAL 被削材质

UEX				
P20 S45C	SCM SK	FC FCD	CU	304
碳素钢	合金钢	铸铁	铜合金	不锈钢
●	●	●	●	●

★ TOLERANCES 公差

Blade diameter 刃部直径	Blade diameter tolerance 刃部直径公差	Shank diameter tolerance 柄部直径公差
Φ1.0~Φ2.9	0~-0.02	H6
Φ3.0~Φ6.0	-0.01~-0.03	
Φ6.5~Φ10.5	-0.01~-0.035	
Φ11.0~Φ16.0	-0.01~-0.04	
Φ17.0~Φ20.0	-0.015~-0.045	

# UEX Long shank 2 flutes square end mills

長柄標準刃 2刃立銑刀

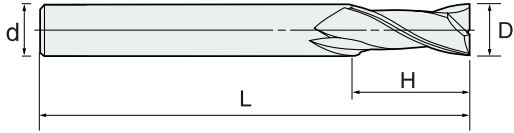

UMG 0.5 μm CO10% HRC-60 AITINL AITINS

B130

Product Code 產品編號	Blade diameter 刃徑	Blade length 刃長	Full 全長	Shank 柄徑	Inventory 庫存	
					AL	AS
UEX2F01003007504	1.0	3	75	4	○	○
UEX2F01504507504	1.5	4.5	75	4	○	○
UEX2F02006007504	2.0	6	75	4	○	○
UEX2F02507007504	2.5	7	75	4	○	○
UEX2F03008007504	3.0	8	75	4	○	○
UEX2F03510007504	3.5	10	75	4	○	○
UEX2F04011007504	4.0	11	75	4	○	○
UEX2F04513007506	4.5	13	75	6	○	○
UEX2F05013007506	5.0	13	75	6	○	○
UEX2F05513007506	5.5	13	75	6	○	○
UEX2F06015007506	6.0	15	75	6	○	○
UEX2F06517007508	6.5	17	75	8	○	○
UEX2F07017007508	7.0	17	75	8	○	○
UEX2F07517007508	7.5	17	75	8	○	○
UEX2F08020007508	8.0	20	75	8	○	○
UEX2F03008010006	3.0	8	100	6	○	○
UEX2F04011010006	4.0	11	100	6	○	○
UEX2F05013010006	5.0	13	100	6	○	○
UEX2F06015010006	6.0	15	100	6	○	○
UEX2F07017010008	7.0	17	100	8	○	○
UEX2F08020010008	8.0	20	100	8	○	○
UEX2F09023010010	9.0	23	100	10	○	○
UEX2F10025010010	10.0	25	100	10	○	○
UEX2F11028010012	11.0	28	100	12	○	○
UEX2F12030010012	12.0	30	100	12	○	○
UEX2F08020015008	8.0	20	150	8	○	○
UEX2F10025015010	10.0	25	150	10	○	○
UEX2F12030015012	12.0	30	150	12	○	○
UEX2F16050015016	16.0	50	150	16	○	○
UEX2F18050015018	18.0	50	150	18	○	○
UEX2F20050015020	20.0	50	150	20	○	○
UEX2F16050020016	16.0	50	200	16	○	○
UEX2F20050020020	20.0	50	200	20	○	○

## ★ WORK MATERIAL 被削材質

UEX				
P20 S45C	SCM SK	FC FCD	CU	304
碳素鋼	合金鋼	鑄鐵	銅合金	不銹鋼
●	●	●	●	●

## ★ TOLERANCES 公差

Blade diameter 刃部直徑	Blade diameter tolerance 刃部直徑公差	Shank diameter tolerance 柄部直徑公差
Φ1.0~Φ2.9	0~-0.02	H6
Φ3.0~Φ6.0	-0.01~-0.03	
Φ6.5~Φ10.5	-0.01~-0.035	
Φ11.0~Φ16.0	-0.01~-0.04	
Φ17.0~Φ20.0	-0.015~-0.045	

# UEX 2 flutes corner radius end mills

圓鼻 2刃立銑刀

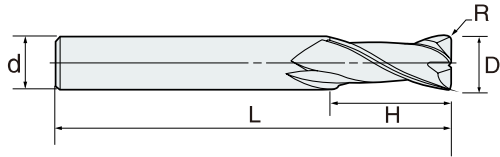

B131

Product Code 產品編號	Blade diameter 刃徑	R	Blade length 刃長	Full 全長	Shank 柄徑	Inventory 庫存	
						AL	AS
UEX2F010R0203005004	1.0	0.2	3	50	4	○	○
UEX2F015R0204005004	1.5	0.2	4	50	4	○	○
UEX2F015R0504005004	1.5	0.5	4	50	4	○	○
UEX2F020R0206005004	2.0	0.2	6	50	4	○	○
UEX2F020R0506005004	2.0	0.5	6	50	4	○	○
UEX2F025R0208005004	2.5	0.2	8	50	4	○	○
UEX2F025R0508005004	2.5	0.5	8	50	4	○	○
UEX2F030R0208005004	3.0	0.2	8	50	4	○	○
UEX2F030R0508005004	3.0	0.5	8	50	4	○	○
UEX2F030R1008005004	3.0	1.0	8	50	4	○	○
UEX2F040R0211005004	4.0	0.2	11	50	4	○	○
UEX2F040R0511005004	4.0	0.5	11	50	4	○	○
UEX2F040R1011005004	4.0	1.0	11	50	4	○	○
UEX2F050R0513005006	5.0	0.5	13	50	6	○	○
UEX2F050R1013005006	5.0	1.0	13	50	6	○	○
UEX2F060R0215005006	6.0	0.2	15	50	6	○	○
UEX2F060R0515005006	6.0	0.5	15	50	6	○	○
UEX2F060R1015005006	6.0	1.0	15	50	6	○	○
UEX2F060R1515005006	6.0	1.5	15	50	6	○	○
UEX2F060R2015005006	6.0	2.0	15	50	6	○	○
UEX2F080R0520006008	8.0	0.5	20	60	8	○	○
UEX2F080R1020006008	8.0	1.0	20	60	8	○	○
UEX2F080R1520006008	8.0	1.5	20	60	8	○	○
UEX2F080R2020006008	8.0	2.0	20	60	8	○	○
UEX2F100R0525007510	10.0	0.5	25	75	10	○	○
UEX2F100R1025007510	10.0	1.0	25	75	10	○	○
UEX2F100R1525007510	10.0	1.5	25	75	10	○	○
UEX2F100R2025007510	10.0	2.0	25	75	10	○	○
UEX2F100R2525007510	10.0	2.5	25	75	10	○	○
UEX2F100R3025007510	10.0	3.0	25	75	10	○	○
UEX2F120R0530007512	12.0	0.5	30	75	12	○	○
UEX2F120R1030007512	12.0	1.0	30	75	12	○	○
UEX2F120R1530007512	12.0	1.5	30	75	12	○	○
UEX2F120R2030007512	12.0	2.0	30	75	12	○	○
UEX2F120R2530007512	12.0	2.5	30	75	12	○	○
UEX2F120R3030007512	12.0	3.0	30	75	12	○	○

## ★ WORK MATERAIL 被削材質

UEX				
P20 S45C	SCM SK	FC FCD	CU	304
碳素鋼	合金鋼	鑄鐵	銅合金	不銹鋼
●	●	●	●	●

## ★ TOLERANCES 公差

Blade diameter 刃部直徑	Blade diameter tolerance 刃部直徑公差	Shank diameter tolerance 柄部直徑公差
Φ1.0~Φ2.9	0~-0.02	H6
Φ3.0~Φ6.0	-0.01~-0.03	
Φ6.5~Φ10.5	-0.01~-0.035	
Φ11.0~Φ12.0	-0.01~-0.04	

# UEX Long shank 2 flutes corner radius end mills

長柄圓鼻2刃立銼刀

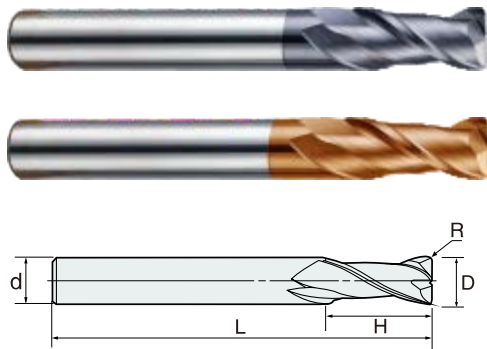

B132

Product Code 產品編號	Blade diameter 刃徑	R	Blade length 刃長	Full 全長	Shank 柄徑	Inventory 庫存	
						AL	AS
UEX2F010R0203007504	1.0	0.2	3	75	4	⊙	⊙
UEX2F015R0204007504	1.5	0.2	4	75	4	⊙	⊙
UEX2F015R0504007504	1.5	0.5	4	75	4	⊙	⊙
UEX2F020R0206007504	2.0	0.2	6	75	4	⊙	⊙
UEX2F020R0506007504	2.0	0.5	6	75	4	⊙	⊙
UEX2F025R0208007504	2.5	0.2	8	75	4	⊙	⊙
UEX2F025R0508007504	2.5	0.5	8	75	4	⊙	⊙
UEX2F030R0208007504	3.0	0.2	8	75	4	⊙	⊙
UEX2F030R0508007504	3.0	0.5	8	75	4	⊙	⊙
UEX2F030R1008007504	3.0	1.0	8	75	4	⊙	⊙
UEX2F040R0211007504	4.0	0.2	11	75	4	⊙	⊙
UEX2F040R0511007504	4.0	0.5	11	75	4	⊙	⊙
UEX2F040R1011007504	4.0	1.0	11	75	4	⊙	⊙
UEX2F050R0513007506	5.0	0.5	13	75	6	⊙	⊙
UEX2F050R1013007506	5.0	1.0	13	75	6	⊙	⊙
UEX2F060R0215007506	6.0	0.2	15	75	6	⊙	⊙
UEX2F060R0515007506	6.0	0.5	15	75	6	⊙	⊙
UEX2F060R1015007506	6.0	1.0	15	75	6	⊙	⊙
UEX2F060R1515007506	6.0	1.5	15	75	6	⊙	⊙
UEX2F060R2015007506	6.0	2.0	15	75	6	⊙	⊙
UEX2F080R0520007508	8.0	0.5	20	75	8	⊙	⊙
UEX2F080R1020007508	8.0	1.0	20	75	8	⊙	⊙
UEX2F080R1520007508	8.0	1.5	20	75	8	⊙	⊙
UEX2F080R2020007508	8.0	2.0	20	75	8	⊙	⊙
UEX2F040R0211010006	4.0	0.2	11	100	6	⊙	⊙
UEX2F040R0511010006	4.0	0.5	11	100	6	⊙	⊙
UEX2F040R1011010006	4.0	1.0	11	100	6	⊙	⊙
UEX2F050R0513010006	5.0	0.5	13	100	6	⊙	⊙
UEX2F050R1013010006	5.0	1.0	13	100	6	⊙	⊙
UEX2F060R0215010006	6.0	0.2	15	100	6	⊙	⊙
UEX2F060R0515010006	6.0	0.5	15	100	6	⊙	⊙
UEX2F060R1015010006	6.0	1.0	15	100	6	⊙	⊙
UEX2F060R1515010006	6.0	1.5	15	100	6	⊙	⊙
UEX2F060R2015010006	6.0	2.0	15	100	6	⊙	⊙
UEX2F080R0520010008	8.0	0.5	20	100	8	⊙	⊙
UEX2F080R1020010008	8.0	1.0	20	100	8	⊙	⊙
UEX2F080R1520010008	8.0	1.5	20	100	8	⊙	⊙
UEX2F080R2020010008	8.0	2.0	20	100	8	⊙	⊙
UEX2F100R0525010010	10.0	0.5	25	100	10	⊙	⊙
UEX2F100R1025010010	10.0	1.0	25	100	10	⊙	⊙
UEX2F100R1525010010	10.0	1.5	25	100	10	⊙	⊙
UEX2F100R2025010010	10.0	2.0	25	100	10	⊙	⊙
UEX2F100R2525010010	10.0	2.5	25	100	10	⊙	⊙
UEX2F100R3025010010	10.0	3.0	25	100	10	⊙	⊙
UEX2F120R0530010012	12.0	0.5	30	100	12	⊙	⊙
UEX2F120R1030010012	12.0	1.0	30	100	12	⊙	⊙
UEX2F120R1530010012	12.0	1.5	30	100	12	⊙	⊙
UEX2F120R2030010012	12.0	2.0	30	100	12	⊙	⊙
UEX2F120R2530010012	12.0	2.5	30	100	12	⊙	⊙
UEX2F120R3030010012	12.0	3.0	30	100	12	⊙	⊙

■Special specifications can be customized. ■特殊規格可訂制。

# UEX 4 flutes square end mills

4刃立銼刀

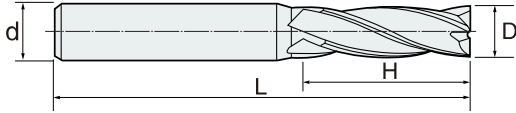

UMG 0.5 μm CO10% HRC-60 AITINL AITINS

B133

Product Code 產品編號	Blade diameter 刃徑	Blade length 刃長	Full 全長	Shank 柄徑	Inventory 庫存	
					AL	AS
UEX4F01003005004	1.0	3	50	4	○	○
UEX4F01504505004	1.5	4.5	50	4	○	○
UEX4F02006005004	2.0	6	50	4	○	○
UEX4F02507005004	2.5	7	50	4	○	○
UEX4F03008005004	3.0	8	50	4	○	○
UEX4F03510005004	3.5	10	50	4	○	○
UEX4F04011005004	4.0	11	50	4	○	○
UEX4F04513005006	4.5	13	50	6	○	○
UEX4F05013005006	5.0	13	50	6	○	○
UEX4F05513005006	5.5	13	50	6	○	○
UEX4F06015005006	6.0	15	50	6	○	○
UEX4F06517006008	6.5	17	60	8	○	○
UEX4F07017006008	7.0	17	60	8	○	○
UEX4F07517006008	7.5	17	60	8	○	○
UEX4F08020006008	8.0	20	60	8	○	○
UEX4F08523007510	8.5	23	75	10	○	○
UEX4F09023007510	9.0	23	75	10	○	○
UEX4F09525007510	9.5	25	75	10	○	○
UEX4F10025007510	10.0	25	75	10	○	○
UEX4F10525007512	10.5	25	75	12	○	○
UEX4F11028007512	11.0	28	75	12	○	○
UEX4F11528007512	11.5	28	75	12	○	○
UEX4F12030007512	12.0	30	75	14	○	○
UEX4F13045010014	13.0	45	100	14	○	○
UEX4F14045010014	14.0	45	100	14	○	○
UEX4F15045010016	15.0	45	100	16	○	○
UEX4F16045010016	16.0	45	100	16	○	○
UEX4F17045010018	17.0	45	100	18	○	○
UEX4F18045010018	18.0	45	100	18	○	○
UEX4F19045010020	19.0	45	100	20	○	○
UEX4F20045010020	20.0	45	100	20	○	○
UEX4F22045010025	22.0	45	100	25	○	○
UEX4F25045010025	25.0	45	100	25	○	○

## ★ WORK MATERIAL 被削材質

UEX				
P20 S45C	SCM SK	FC FCD	CU	304
碳素鋼	合金鋼	鑄鐵	銅合金	不銹鋼
●	●	●	●	●

## ★ TOLERANCES 公差

Blade diameter 刃部直徑	Blade diameter tolerance 刃部直徑公差	Shank diameter tolerance 柄部直徑公差
Φ1.0~Φ2.9	0~-0.02	H6
Φ3.0~Φ6.4	-0.01~-0.03	
Φ6.5~Φ10.9	-0.01~-0.035	
Φ11.0~Φ16.5	-0.01~-0.04	
Φ17.0~Φ20.0	-0.015~-0.045	
Φ20.5~Φ25.0	-0.015~-0.05	



# UEX Long shank 4 flutes square end mills

長柄標準刃 4刃立銑刀

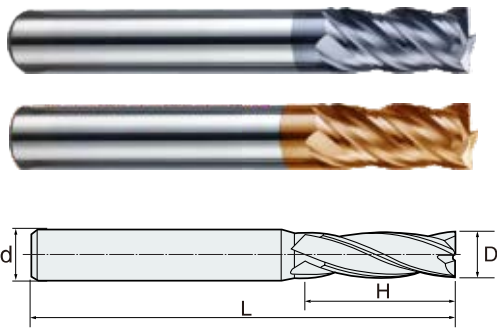

UMG 0.5 μm CO10% HRC-60 AITINL AITINS

B134

Product Code 產品編號	Blade diameter 刃徑	Blade length 刃長	Full 全長	Shank 柄徑	Inventory 庫存	
					AL	AS
UEX4F01003007504	1.0	3	75	4	○	○
UEX4F01504507504	1.5	4.5	75	4	○	○
UEX4F02006007504	2.0	6	75	4	○	○
UEX4F02507007504	2.5	7	75	4	○	○
UEX4F03008007504	3.0	8	75	4	○	○
UEX4F03510007504	3.5	10	75	4	○	○
UEX4F04011007504	4.0	11	75	4	○	○
UEX4F04513007506	4.5	13	75	6	○	○
UEX4F05013007506	5.0	13	75	6	○	○
UEX4F05513007506	5.5	13	75	6	○	○
UEX4F06015007506	6.0	15	75	6	○	○
UEX4F06517007508	6.5	17	75	8	○	○
UEX4F07017007508	7.0	17	75	8	○	○
UEX4F07517007508	7.5	17	75	8	○	○
UEX4F08020007508	8.0	20	75	8	○	○
UEX4F03008010006	3.0	8	100	6	○	○
UEX4F04011010006	4.0	11	100	6	○	○
UEX4F05013010006	5.0	13	100	6	○	○
UEX4F06015010006	6.0	15	100	6	○	○
UEX4F07017010008	7.0	17	100	8	○	○
UEX4F08020010008	8.0	20	100	8	○	○
UEX4F09023010010	9.0	23	100	10	○	○
UEX4F10025010010	10.0	25	100	10	○	○
UEX4F11028010012	11.0	28	100	12	○	○
UEX4F12030010012	12.0	30	100	12	○	○
UEX4F08020015008	8.0	20	150	8	○	○
UEX4F10025015010	10.0	25	150	10	○	○
UEX4F12030015012	12.0	30	150	12	○	○
UEX4F16050015016	16.0	50	150	16	○	○
UEX4F18050015018	18.0	50	150	18	○	○
UEX4F20050015020	20.0	50	150	20	○	○
UEX4F16050020016	16.0	50	200	16	○	○
UEX4F20050020020	20.0	50	200	20	○	○

## ★ WORK MATERIAL 被削材質

UEX				
P20 S45C	SCM SK	FC FCD	CU	304
碳素鋼	合金鋼	鑄鐵	銅合金	不銹鋼
●	●	●	●	●

## ★ TOLERANCES 公差

Blade diameter 刃部直徑	Blade diameter tolerance 刃部直徑公差	Shank diameter tolerance 柄部直徑公差
Φ1.0~Φ2.9	0~-0.02	H6
Φ3.0~Φ6.0	-0.01~-0.03	
Φ6.5~Φ10.5	-0.01~-0.035	
Φ11.0~Φ16.0	-0.01~-0.04	
Φ17.0~Φ20.0	-0.015~-0.045	

# UEX 4 flutes corner radius end mills

圓鼻 4刃立銑刀

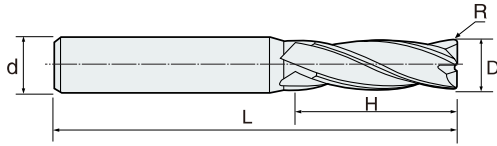

B135

Product Code 產品編號	Blade diameter 刃徑	R	Blade length 刃長	Full 全長	Shank 柄徑	Inventory 庫存	
						AL	AS
UEX4F010R0203005004	1.0	0.2	3	50	4	○	○
UEX4F015R0204005004	1.5	0.2	4	50	4	○	○
UEX4F015R0504005004	1.5	0.5	4	50	4	○	○
UEX4F020R0206005004	2.0	0.2	6	50	4	○	○
UEX4F020R0506005004	2.0	0.5	6	50	4	○	○
UEX4F025R0208005004	2.5	0.2	8	50	4	○	○
UEX4F025R0508005004	2.5	0.5	8	50	4	○	○
UEX4F030R0208005004	3.0	0.2	8	50	4	○	○
UEX4F030R0508005004	3.0	0.5	8	50	4	○	○
UEX4F030R1008005004	3.0	1.0	8	50	4	○	○
UEX4F040R0211005004	4.0	0.2	11	50	4	○	○
UEX4F040R0511005004	4.0	0.5	11	50	4	○	○
UEX4F040R1011005004	4.0	1.0	11	50	4	○	○
UEX4F050R0513005006	5.0	0.5	13	50	6	○	○
UEX4F050R1013005006	5.0	1.0	13	50	6	○	○
UEX4F060R0215005006	6.0	0.2	15	50	6	○	○
UEX4F060R0515005006	6.0	0.5	15	50	6	○	○
UEX4F060R1015005006	6.0	1.0	15	50	6	○	○
UEX4F060R1515005006	6.0	1.5	15	50	6	○	○
UEX4F060R2015005006	6.0	2.0	15	50	6	○	○
UEX4F080R0520006008	8.0	0.5	20	60	8	○	○
UEX4F080R1020006008	8.0	1.0	20	60	8	○	○
UEX4F080R1520006008	8.0	1.5	20	60	8	○	○
UEX4F080R2020006008	8.0	2.0	20	60	8	○	○
UEX4F100R0525007510	10.0	0.5	25	75	10	○	○
UEX4F100R1025007510	10.0	1.0	25	75	10	○	○
UEX4F100R1525007510	10.0	1.5	25	75	10	○	○
UEX4F100R2025007510	10.0	2.0	25	75	10	○	○
UEX4F100R2525007510	10.0	2.5	25	75	10	○	○
UEX4F100R3025007510	10.0	3.0	25	75	10	○	○
UEX4F120R0530007512	12.0	0.5	30	75	12	○	○
UEX4F120R1030007512	12.0	1.0	30	75	12	○	○
UEX4F120R1530007512	12.0	1.5	30	75	12	○	○
UEX4F120R2030007512	12.0	2.0	30	75	12	○	○
UEX4F120R2530007512	12.0	2.5	30	75	12	○	○
UEX4F120R3030007512	12.0	3.0	30	75	12	○	○

## ★ WORK MATERAIL 被削材質

UEX				
P20 S45C	SCM SK	FC FCD	CU	304
碳素鋼	合金鋼	鑄鐵	銅合金	不銹鋼
●	●	●	●	●

## ★ TOLERANCES 公差

Blade diameter 刃部直徑	Blade diameter tolerance 刃部直徑公差	Shank diameter tolerance 柄部直徑公差
Φ1.0~Φ2.9	0~-0.02	H6
Φ3.0~Φ6.0	-0.01~-0.03	
Φ6.5~Φ10.5	-0.01~-0.035	
Φ11.0~Φ12.0	-0.01~-0.04	

# UEX Long shank 4 flutes corner radius end mills

長柄圓鼻4刃立銼刀

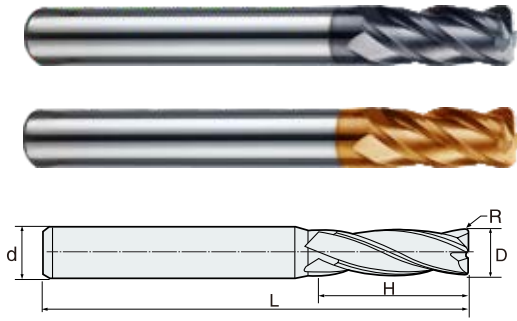

B136

Product Code 產品編號	Blade diameter 刃徑	R	Blade length 刃長	Full 全長	Shank 柄徑	Inventory 庫存	
						AL	AS
UEX4F010R0203007504	1.0	0.2	3	75	4	○	○
UEX4F015R0204007504	1.5	0.2	4	75	4	○	○
UEX4F015R0504007504	1.5	0.5	4	75	4	○	○
UEX4F020R0206007504	2.0	0.2	6	75	4	○	○
UEX4F020R0506007504	2.0	0.5	6	75	4	○	○
UEX4F025R0208007504	2.5	0.2	8	75	4	○	○
UEX4F025R0508007504	2.5	0.5	8	75	4	○	○
UEX4F030R0208007504	3.0	0.2	8	75	4	○	○
UEX4F030R0508007504	3.0	0.5	8	75	4	○	○
UEX4F030R1008007504	3.0	1.0	8	75	4	○	○
UEX4F040R0211007504	4.0	0.2	11	75	4	○	○
UEX4F040R0511007504	4.0	0.5	11	75	4	○	○
UEX4F040R1011007504	4.0	1.0	11	75	4	○	○
UEX4F050R0513007506	5.0	0.5	13	75	6	○	○
UEX4F050R1013007506	5.0	1.0	13	75	6	○	○
UEX4F060R0215007506	6.0	0.2	15	75	6	○	○
UEX4F060R0515007506	6.0	0.5	15	75	6	○	○
UEX4F060R1015007506	6.0	1.0	15	75	6	○	○
UEX4F060R1515007506	6.0	1.5	15	75	6	○	○
UEX4F060R2015007506	6.0	2.0	15	75	6	○	○
UEX4F080R0520007508	8.0	0.5	20	75	8	○	○
UEX4F080R1020007508	8.0	1.0	20	75	8	○	○
UEX4F080R1520007508	8.0	1.5	20	75	8	○	○
UEX4F080R2020007508	8.0	2.0	20	75	8	○	○
UEX4F040R0211010006	4.0	0.2	11	100	6	○	○
UEX4F040R0511010006	4.0	0.5	11	100	6	○	○
UEX4F040R1011010006	4.0	1.0	11	100	6	○	○
UEX4F050R0513010006	5.0	0.5	13	100	6	○	○
UEX4F050R1013010006	5.0	1.0	13	100	6	○	○
UEX4F060R0215010006	6.0	0.2	15	100	6	○	○
UEX4F060R0515010006	6.0	0.5	15	100	6	○	○
UEX4F060R1015010006	6.0	1.0	15	100	6	○	○
UEX4F060R1515010006	6.0	1.5	15	100	6	○	○
UEX4F060R2015010006	6.0	2.0	15	100	6	○	○
UEX4F080R0520010008	8.0	0.5	20	100	8	○	○
UEX4F080R1020010008	8.0	1.0	20	100	8	○	○
UEX4F080R1520010008	8.0	1.5	20	100	8	○	○
UEX4F080R2020010008	8.0	2.0	20	100	8	○	○
UEX4F100R0525010010	10.0	0.5	25	100	10	○	○
UEX4F100R1025010010	10.0	1.0	25	100	10	○	○
UEX4F100R1525010010	10.0	1.5	25	100	10	○	○
UEX4F100R2025010010	10.0	2.0	25	100	10	○	○
UEX4F100R2525010010	10.0	2.5	25	100	10	○	○
UEX4F100R3025010010	10.0	3.0	25	100	10	○	○
UEX4F120R0530010012	12.0	0.5	30	100	12	○	○
UEX4F120R1030010012	12.0	1.0	30	100	12	○	○
UEX4F120R1530010012	12.0	1.5	30	100	12	○	○
UEX4F120R2030010012	12.0	2.0	30	100	12	○	○
UEX4F120R2530010012	12.0	2.5	30	100	12	○	○
UEX4F120R3030010012	12.0	3.0	30	100	12	○	○

■ Special specifications can be customized. ■ 特殊規格可訂制。

# UEX 2 flutes ball nose end mills

2刃球型立銑刀



UMG 0.5 μm CO10% HRC-60 AITINL AITINS

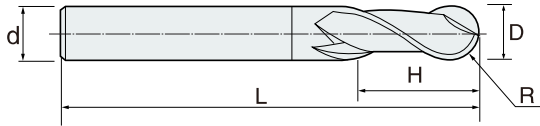

B137

Product Code 產品編號	R Blade R 徑	Blade length 刃長	Full 全長	Shank 柄徑	Inventory 庫存	
					AL	AS
UEX2FR005002005004	R0.50	2.0	50	4	○	○
UEX2FR007503005004	R0.75	3.0	50	4	○	○
UEX2FR010004005004	R1.00	4.0	50	4	○	○
UEX2FR012505005004	R1.25	5.0	50	4	○	○
UEX2FR015006005004	R1.50	6.0	50	4	○	○
UEX2FR017507005004	R1.75	7.0	50	4	○	○
UEX2FR020008005004	R2.00	8.0	50	4	○	○
UEX2FR005002005006	R0.50	2.0	50	6	○	○
UEX2FR007503005006	R0.75	3.0	50	6	○	○
UEX2FR010004005006	R1.00	4.0	50	6	○	○
UEX2FR012505005006	R1.25	5.0	50	6	○	○
UEX2FR015006005006	R1.50	6.0	50	6	○	○
UEX2FR017507005006	R1.75	7.0	50	6	○	○
UEX2FR020008005006	R2.00	8.0	50	6	○	○
UEX2FR022509005006	R2.25	9.0	50	6	○	○
UEX2FR025010005006	R2.50	10.0	50	6	○	○
UEX2FR027511005006	R2.75	11.0	50	6	○	○
UEX2FR030012005006	R3.00	12.0	50	6	○	○
UEX2FR032513006008	R3.25	13.0	60	8	○	○
UEX2FR035014006008	R3.50	14.0	60	8	○	○
UEX2FR037515006008	R3.75	15.0	60	8	○	○
UEX2FR040016006008	R4.00	16.0	60	8	○	○
UEX2FR045018007510	R4.50	18.0	75	10	○	○
UEX2FR050020007510	R5.00	20.0	75	10	○	○
UEX2FR060024007512	R6.00	24.0	75	12	○	○
UEX2FR070028010014	R7.00	28.0	100	14	○	○
UEX2FR080032010016	R8.00	32.0	100	16	○	○
UEX2FR090036010018	R9.00	36.0	100	18	○	○
UEX2FR100040010020	R10.0	40.0	100	20	○	○
UEX2FR125050010025	R12.5	50.0	100	25	○	○

## ★ WORK MATERAIL 被削材質

UEX				
P20 S45C	SCM SK	FC FCD	CU	304
碳素鋼	合金鋼	鑄鐵	銅合金	不銹鋼
●	●	●	●	●

R	R diameter tolerance
R	R ± 0.015

## ★ TOLERANCES 公差

Blade diameter 刃部直徑	Blade diameter tolerance 刃部直徑公差	Shank diameter tolerance 柄部直徑公差
Φ1.0~Φ2.9	0~-0.02	H6
Φ3.0~Φ6.4	-0.01~-0.03	
Φ6.5~Φ10.9	-0.01~-0.035	
Φ11.0~Φ16.5	-0.01~-0.04	
Φ17.0~Φ20.0	-0.015~-0.045	
Φ20.5~Φ25.0	-0.015~-0.05	

# UEX Long shank 2 flutes ball nose end mills

長柄 2刃球型立銼刀



UMG 0.5 μm CO10% HRC-60 AITINL AITINS

B138

Product Code 產品編號	R Blade R 徑	Blade length 刃長	Full 全長	Shank 柄徑	Inventory 庫存	
					AL	AS
UEX2FR005002007504	R0.50	2	75	4	○	○
UEX2FR007503007504	R0.75	3	75	4	○	○
UEX2FR010004007504	R1.00	4	75	4	○	○
UEX2FR012505007504	R1.25	5	75	4	○	○
UEX2FR015006007504	R1.50	6	75	4	○	○
UEX2FR017507007504	R1.75	7	75	4	○	○
UEX2FR020008007504	R2.00	8	75	4	○	○
UEX2FR022509007506	R2.25	9	75	6	○	○
UEX2FR025010007506	R2.50	10	75	6	○	○
UEX2FR027511007506	R2.75	11	75	6	○	○
UEX2FR030012007506	R3.00	12	75	6	○	○
UEX2FR040016007508	R4.00	16	75	8	○	○
UEX2FR005002010006	R0.50	2	100	6	○	○
UEX2FR007503010006	R0.75	3	100	6	○	○
UEX2FR010004010006	R1.00	4	100	6	○	○
UEX2FR012505010006	R1.25	5	100	6	○	○
UEX2FR015006010006	R1.50	6	100	6	○	○
UEX2FR017507010006	R1.75	7	100	6	○	○
UEX2FR020008010006	R2.00	8	100	6	○	○
UEX2FR022509010006	R2.25	9	100	6	○	○
UEX2FR025010010006	R2.50	10	100	6	○	○
UEX2FR027511010006	R2.75	11	100	6	○	○
UEX2FR030012010006	R3.00	12	100	6	○	○
UEX2FR040016010008	R4.00	16	100	8	○	○
UEX2FR050020010010	R5.00	20	100	10	○	○
UEX2FR060024010012	R6.00	24	100	12	○	○
UEX2FR030012015006	R3.00	12	150	6	○	○
UEX2FR040016015008	R4.00	16	150	8	○	○
UEX2FR050020015010	R5.00	20	150	10	○	○
UEX2FR060024015012	R6.00	24	150	12	○	○
UEX2FR070028015014	R7.00	28	150	14	○	○
UEX2FR080032015016	R8.00	32	150	16	○	○
UEX2FR100040015020	R10.00	40	150	20	○	○
UEX2FR040016020008	R4.00	16	200	8	○	○
UEX2FR050020020010	R5.00	20	200	10	○	○
UEX2FR060024020012	R6.00	24	200	12	○	○
UEX2FR070028020014	R7.00	28	200	14	○	○
UEX2FR080032020016	R8.00	32	200	16	○	○
UEX2FR100040020020	R10.00	40	200	20	○	○

## ★ WORK MATERAIL 被削材質

UEX				
P20 S45C	SCM SK	FC FCD	CU	304
碳素鋼	合金鋼	鑄鐵	銅合金	不銹鋼
●	●	●	●	●

R R diameter tolerance

R R ± 0.015

## ★ TOLERANCES 公差

Blade diameter 刃部直徑	Blade diameter tolerance 刃部直徑公差	Shank diameter tolerance 柄部直徑公差
Φ1.0~Φ2.9	0~-0.02	H6
Φ3.0~Φ6.4	-0.01~-0.03	
Φ6.5~Φ10.9	-0.01~-0.035	
Φ11.0~Φ16.5	-0.01~-0.04	
Φ17.0~Φ20.0	-0.015~-0.045	
Φ20.5~Φ25.0	-0.015~-0.05	

# UEX4 flutes high strength flat end mills

四刃強力平底銑刀



B139



UMG 0.5 μm CO10% HRC-60 AITINL AITINS

Product Code 產品編號	Blade diameter 刃徑	Blade length 刃長	Effective length 有效長	Full 全長	Shank 柄徑	Inventory 庫存	
						AL	AS
UEX4F01001502505004	1.0	1.5	2.5	50	4	○	○
UEX4F02003005005004	2.0	3.0	5.0	50	4	○	○
UEX4F03004507505006	3.0	4.5	7.5	50	6	○	○
UEX4F04006010005006	4.0	6.0	10.0	50	6	○	○
UEX4F05007512505006	5.0	7.5	12.5	50	6	○	○
UEX4F06009015005006	6.0	9.0	15.0	50	6	○	○
UEX4F08012020006008	8.0	12.0	20.0	60	8	○	○
UEX4F10015025075010	10.0	15.0	25.0	75	10	○	○
UEX4F12018030075012	12.0	18.0	30.0	75	12	○	○
UEX4F16024040100016	16.0	24.0	40.0	100	16	○	○
UEX4F20030050100020	20.0	30.0	50.0	100	20	○	○

Product Code 產品編號	Blade diameter 刃徑	Blade length 刃長	Effective length 有效長	Full 全長	Shank 柄徑	Inventory 庫存	
						AL	AS
UEX4F1/8-B	1/8	5/32	1/2	2-1/2	1/4	○	○
UEX4F3/16-B	3/16	7/32	3/4	2-1/2	1/4	○	○
UEX4F1/4-B	1/4	9/32	3/4	2-1/2	1/4	○	○
UEX4F5/16-B	5/16	13/32	1	2-1/2	5/16	○	○
UEX4F3/8-B	3/8	15/32	1	2-1/2	3/8	○	○
UEX4F1/2-B	1/2	5/8	1-1/4	3	1/2	○	○
UEX4F5/8-B	5/8	3/4	1-1/2	3-1/2	5/8	○	○
UEX4F3/4-B	3/4	15/16	1-3/4	4	3/4	○	○

## ★ WORK MATERIAL 被削材質

UEX

P20 S45C	SCM SK	FC FCD	CU	304
碳素鋼	合金鋼	鑄鐵	銅合金	不銹鋼
●	●	●	●	●

Working material 被切材質	Hardened steel 淬火鋼	Hardened steel 淬火鋼	Hardened steel 淬火鋼
Material code 材質編碼	SKT,SKD	SKT,SKD	SKT,SKD
Hardness grade 硬度等級	HRC 45	HRC 55	HRC 60
Vc	160M/min	150M/min	99M/min

## ★ TOLERANCES 公差

Blade diameter 刃部直徑	Blade diameter tolerance 刃部直徑公差
Φ ≤ 12.0	0~-0.02
Φ > 12.0	0~-0.03

Diameter 直徑	R.P.M		Feed (mm/mm)		R.P.M		Feed (mm/mm)	
	R.P.M	Feed (mm/mm)	R.P.M	Feed (mm/mm)	R.P.M	Feed (mm/mm)	R.P.M	Feed (mm/mm)
6MM	8,500	2,450	7,950	2,000	5,300	1,210		
8MM	6,350	2,440	5,950	1,995	4,000	1,215		
10MM	5,100	2,450	4,700	1,970	3,200	1,215		
12MM	4,250	2,450	3,950	1,985	2,650	1,210		
14MM	3,600	2,420	3,400	1,995	2,250	1,200		
16MM	3,150	2,420	3,000	2,000	1,950	1,285		
18MM	2,800	2,420	2,650	2,000	1,750	1,200		
20MM	2,500	2,400	2,350	1,970	1,550	1,180		
25MM	2,000	2,400	1,900	1,990	1,250	1,190		



Milling amount  
(mm)

ap	ae
1.0D	0.02D
aeMax=0.2mm以下	

ap	ae
1.0D	0.01D
aeMax=0.2mm以下	

ap	ae
1.0D	0.01D
aeMax=0.2mm以下	

The feed & RPM may be changed depending on the M/C Conditions, Lubricating & Cooling systems.

# UEX2 flutes high strength ball nose end mills

二刃強力球頭銼刀

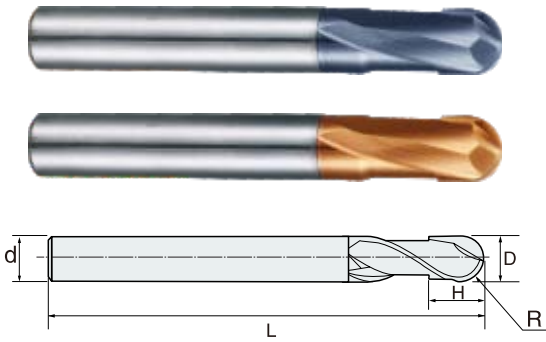

UMG 0.5 μm CO10% HRC-60 AITINL AITINS

B140

Product Code 產品編號	Radius 半徑	Blade diameter 刃徑	Blade length 刃長	Effective length 有效長	Full 全長	Shank 柄徑	Inventory 庫存	
							AL	AS
UEX2FR0050100100205004	0.50R	1.0	1.0	2	50	4	○	○
UEX2FR0075150150305004	0.75R	1.5	1.5	3	50	4	○	○
UEX2FR0100200200405006	1.00R	2.0	2.0	4	50	6	○	○
UEX2FR0150300300605006	1.50R	3.0	3.0	6	50	6	○	○
UEX2FR0200400400805006	2.00R	4.0	4.0	8	50	6	○	○
UEX2FR0250500501005006	2.50R	5.0	5.0	10	50	6	○	○
UEX2FR0300600601205006	3.00R	6.0	6.0	12	50	6	○	○
UEX2FR0400800801606008	4.00R	8.0	8.0	16	60	8	○	○
UEX2FR0501001002007510	5.00R	10.0	10.0	20	75	10	○	○
UEX2FR0601201202407512	6.00R	12.0	12.0	24	75	12	○	○
UEX2FR0801601603210016	8.00R	16.0	16.0	32	100	16	○	○

## ★ WORK MATERIAL 被削材質

UEX				
P20 S45C	SCM SK	FC FCD	CU	304
碳素鋼	合金鋼	鑄鐵	銅合金	不銹鋼
●	●	●	●	●

Working material 被切材質	Hardened steel 淬火鋼	Hardened steel 淬火鋼	Hardened steel 淬火鋼
Material code 材質編碼	SKT,SKD	SKT,SKD	SKT,SKD
Hardness grade 硬度等級	HRC 45	HRC 55	HRC 60
Vc	190M/min	175M/min	95M/min

## ★ TOLERANCES 公差

Blade diameter 刃部直徑	Blade diameter tolerance 刃部直徑公差
$\Phi \leq 12.0$	$R \pm 0.01$
$\Phi > 12.0$	$R \pm 0.015$

Diameter 直徑	R.P.M		Feed (mm/mm)		R.P.M		Feed (mm/mm)	
	R.P.M	Feed (mm/mm)	R.P.M	Feed (mm/mm)	R.P.M	Feed (mm/mm)	R.P.M	Feed (mm/mm)
0.5R	32,000	960	30,000	850	25,500	500		
1.0R	31,500	1,900	28,500	1,880	15,500	600		
1.5R	21,000	2,080	19,000	1,880	10,500	625		
2.0R	15,500	2,050	14,000	1,850	7,950	630		
2.5R	12,500	2,060	11,000	1,815	6,350	630		
3.0R	10,500	2,080	9,500	1,880	5,300	630		
4.0R	7,950	1,550	7,150	1,400	3,950	470		
5.0R	6,350	1,250	5,700	1,100	3,150	375		
6.0R	5,300	1,050	4,750	950	2,650	315		
8.0R	3,950	790	3,550	710	1,950	230		

Milling amount  
(mm)

	$a_p$	$P_f$
$R \leq 8$	0.02D	0.1D
$R > 8$	0.32mm	0.1D

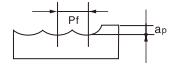

The feed & RPM may be changed depending on the M/C Conditions, Lubricating & Cooling systems.

# UEX4 flutes high strength corner radius end mills

四刃強力圓鼻銼刀

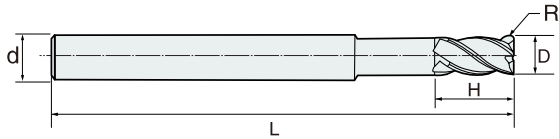

UMG 0.5 μm CO10% HRC-60 AITINL AITINS

B141

Product Code 產品編號	Radius 半徑	Blade diameter 刃徑	Blade length 刃長	Effective length 有效長	Full 全長	Shank 柄徑	Inventory 庫存	
							AL	AS
UEX4F030R01003005006	0.1R	3	3	7.5	50	6	○	○
UEX4F030R05003005006	0.5R	3	3	7.5	50	6	○	○
UEX4F040R02004005006	0.2R	4	4	10.0	50	6	○	○
UEX4F040R05004005006	0.5R	4	4	10.0	50	6	○	○
UEX4F050R02005005006	0.2R	5	5	12.5	50	6	○	○
UEX4F050R05005005006	0.5R	5	5	12.5	50	6	○	○
UEX4F060R02006005006	0.2R	6	6	15.0	50	6	○	○
UEX4F060R05006005006	0.5R	6	6	15.0	50	6	○	○
UEX4F060R10006005006	1.0R	6	6	15.0	50	6	○	○
UEX4F080R03008006008	0.3R	8	8	20.0	60	8	○	○
UEX4F080R05008006008	0.5R	8	8	20.0	60	8	○	○
UEX4F080R10008006008	1.0R	8	8	20.0	60	8	○	○
UEX4F080R15008006008	1.5R	8	8	20.0	60	8	○	○
UEX4F100R03010007510	0.3R	10	10	25.0	75	10	○	○
UEX4F100R05010007510	0.5R	10	10	25.0	75	10	○	○
UEX4F100R10010007510	1.0R	10	10	25.0	75	10	○	○
UEX4F100R15010007510	1.5R	10	10	25.0	75	10	○	○
UEX4F100R20010007510	2.0R	10	10	25.0	75	10	○	○
UEX4F120R03012007512	0.3R	12	12	30.0	75	12	○	○
UEX4F120R05012007512	0.5R	12	12	30.0	75	12	○	○
UEX4F120R10012007512	1.0R	12	12	30.0	75	12	○	○
UEX4F120R15012007512	1.5R	12	12	30.0	75	12	○	○
UEX4F120R20012007512	2.0R	12	12	30.0	75	12	○	○

## ★ WORK MATERIAL 被削材質

UEX				
P20 S45C	SCM SK	FC FCD	CU	304
碳素鋼	合金鋼	鑄鐵	銅合金	不銹鋼
●	●	●	●	●

Working material 被削材質	Hardened steel 淬火鋼	Hardened steel 淬火鋼	Hardened steel 淬火鋼
Material code 材質編碼	SKT,SKD	SKT,SKD	SKT,SKD
Hardness grade 硬度等級	HRC 35	HRC 45	HRC 55
Vc	110M/min	95M/min	79M/min

Diameter 直徑	R.P.M	Feed (mm/mm)	R.P.M	Feed (mm/mm)	R.P.M	Feed (mm/mm)
3MM	1,180	1,150	10,000	830	8,400	500
4MM	8,800	1,070	7,600	780	6,300	460
5MM	7,000	990	6,000	730	5,000	420
6MM	5,900	910	5,000	660	4,200	400
8MM	4,400	830	3,800	610	3,200	400
10MM	3,500	830	3,000	610	2,550	400
12MM	2,900	830	2,500	610	2,100	400

## ★ TOLERANCES 公差

Blade diameter 刃部直徑	Blade diameter tolerance 刃部直徑公差
Φ ≤ 12.0	0~-0.02
Φ > 12.0	0~-0.03

R	R diameter tolerance
R	R ± 0.015

Milling amount (mm)

	a <sub>a</sub>	a <sub>r</sub>
D < Φ 6	0.9D	0.01D
Φ 6 ≤ D	0.9D	0.02D



The feed & RPM may be changed depending on the M/C Conditions, Lubricating & Cooling systems.